

Residential standby system RS12000



Cummins Onan

Performance you rely on.™



Features and benefits

- Very quiet operation - 64 dB(A) at 7 m at full load
- Internet remote monitoring and email notification
- Automatic load management - The intelligent generator control automatically manages non-essential household loads for maximum utilization of generator power
- Powered by Subaru EH 72 engine with Cummins Onan designed fuel system
- Cummins Onan designed alternator and electronic control
- Powerful motor starting - starts and runs a 4 ton A/C* under full pre-load
- 120 volt GFCI protected outlet on genset
- Self-diagnostic capability
- Service and maintenance information displayed on in home display
- Easy installation with innovative molded polymer installation base - no need for a concrete pad

- Electronic governor for precise frequency control
- Flexible 20 inch fuel line provided with genset
- Generator designed and manufactured in the USA
- Emissions certified (60 Hz models)
- UL 2200, CUL and CSA listed generator and transfer switch for your protection
- Utility grade power output, less than 5% THD.

Weight, size and sound level

Weight: 460 lb (209 kg)

Size: Length 48 in (1219 mm), width 34 in (864 mm), height 31.5 in (800 mm)

Generator w/cover: length 53 in (1346 mm), width 43 in (1092 mm), height 31.5 in (800 mm)

Sound: 64 dB(A) at 23 ft (7 m) at full load

Models and ratings

| Order model | Fuel | Voltage | Rated kW** | Rated amps** | Circuit breaker |
|--------------------|-------------|---------|------------|--------------|-----------------|
| 12GSAA-6707 | Natural gas | 120/240 | 10.5 kW | 87.5/43.75 | 50 A, 2 pole |
| 12GSAA-6707 | LP vapor | 120/240 | 12 kW | 100/50 | 50 A, 2 pole |

* Derating guidelines: Full rated power available at 60 °F (15.5 °C) at sea level. Derate 3.5% for each 1000 ft (304.8 m) above sea level and 1.5% for each 10 °F (-12.5 °C) increase in ambient temperature above 60 °F (15.5 °C)

** Prototype tested @ 110 °F (43 °C) with TRANE® 4 ton A/C unit (model 4TCX3048A1000A) with an additional 5 kW pre-load applied. Contact an HVAC specialist for proper generator sizing guidelines.

Cummins®, Onan®, the "C" logo and Performance you rely on.™ are servicemarks, trademarks and/or registered trademarks of Cummins Inc. Specifications subject to change without notice.

Other company, product or service names may be trademarks or service marks of others.

©2008 Cummins Power Generation. All Rights Reserved.

A-1534b (4/08)

Engine

Model: Subaru EH 72, 4-cycle, air-cooled, 2-cylinders OHV

Compression ratio: 8.3:1

Displacement: 40.9 cu in (720 cc)

Cooling air volume: 759 cfm

Oil sump capacity: 1.80 qt (1.7 L) with filter

Operating speed: 3600 rpm

Fuel supply pressure: NG 5-11 in H₂O, LP 7-11 in H₂O

- Cummins Onan designed fuel system for max power output and durability
- Integrated oil drain valve and extension tube included
- Simple fuel conversion between natural gas and LP
- 15 A battery charger
- Highly reliable solenoid shift starter
- Transistorized magneto ignition
- Automotive-style lubrication system
- Oil cooler
- Spin-on oil filter
- Electronic governor
- Large-capacity air cleaner
- CARB Certified, EPA Certified

Weather protective sound enclosure

- Thick 11 gauge double wall aluminum enclosure with resilient architectural grade powder coat paint
- Durable polypropylene base eliminates need for concrete pad
- UL Listed, impact resistant, fully colored, automotive grade polypropylene cover with UV stabilizer
- All maintenance points are accessible without the use of tools
- "Under the hood" oil dipstick check and fill
- Electrical stub-up and side knockouts provided on genset for installation flexibility
- Patented, innovative, compact and neighborhood friendly design blends into any residential setting
 - Rust proof design
 - No exposed fasteners
 - Key lockable
 - High intake and exhaust to reduce rain ingestion and snow blockage

Control system

- Electronic control with self diagnostics and generator set protection and safety features included
- Automatically identifies power outage and starts generator
- Microprocessor control manages generator set operation, fault detection and service diagnostics
- Illuminated run/off/auto switch
- 50 A UL Listed circuit breaker
- Convenient access to all connection points
- Fully automatic operation

Exhaust muffler

- Corrosion resistant stainless steel muffler manifold and body
- Low noise

Transfer switch (Sold Separately)

- 100 and 200 amp automatic transfer switch NEMA 3R.
- Fully automatic operation with Cummins Onan RSS model automatic transfer switch.
- Reduces installation time with indoor/outdoor flexibility and whole house install.
- Two amp trickle battery charger included
- UL 1008 Listed: Service Entrance Rated, RSS100-6868, RSS200-6869
- CSA Approved and UL 1008 Listed: RSS100-6634, RSS200-6635

Internet/email capability

- Sends you or your service technician an email if service or maintenance is required and allows user to check on home and family from anywhere in the world in the event of an emergency.
- Reference Installation/Operators Manual 983-0603 for additional details.

In-home display



- Wired in-home LCD display is offered standard on every set.
- Reliably hardwired to genset battery and charging system.
- Easy set weekly exerciser clock.
- Start and stop genset from comfort of your own home.
- Displays maintenance and service reminders.
- Percent load is displayed allowing user to manage load.

Average fuel consumption:

| Fuel consumption-natural gas | Load: | 1/4 | 1/2 | 3/4 | Full |
|---|----------------------|-----|-----|------|------|
| | ft ³ /hr: | 103 | 122 | 172 | 191 |
| | m ³ /hr: | 2.9 | 3.5 | 4.19 | 5.4 |
| | Kg/hr | 2.1 | 2.5 | 3.5 | 3.9 |
| Nominal fuel rating - 37 MJ/m ³ (1000 Btu/ft ³). | | | | | |

| Fuel consumption-LP vapor | Load: | 1/4 | 1/2 | 3/4 | Full | Conversion factor |
|---|----------------------|-----|-----|-----|------|-------------------------------|
| | ft ³ /hr: | 42 | 53 | 71 | 88 | 8.58 ft ³ = 1 lb |
| | m ³ /hr: | 1.2 | 1.5 | 2.0 | 2.5 | 0.535 m ³ = 1 kg |
| | Gal/hr: | 1.2 | 1.5 | 2.0 | 2.4 | 36.39 ft ³ = 1 Gal |
| | L/hr: | 4.5 | 5.7 | 7.6 | 9.1 | |
| | Kg/hr | 2.2 | 2.8 | 3.7 | 4.7 | |
| Nominal fuel rating - 93 MJ/m ³ (2500 Btu/ft ³). | | | | | | |

Alternator details

Design: Cummins Onan 2-pole, self-excited revolving field. Permanently aligned to engine by a tapered shaft.
Clean utility grade power – Less than 5% THD (total harmonic distortion). Computer and motor friendly power output. Electronic speed and voltage control.
Insulation system and temperature rise: Class H insulation per NEMA MG-1-1-66.
Cooling: Direct-drive, centrifugal blower.
Rotor: Laminated electrical steel assembly skewed for improved voltage waveform, heavy insulated copper wire windings.

Bearing: Double-sealed pre-lubricated ball bearing.
DC brushes: Electrographitic, long life, easily serviced.

Generator set performance

Voltage: 120/240 V AC, single phase, 1.0 pf.
Voltage regulation: ±1.5% no load to full load.
Frequency regulation: Isochronous, 0% no load to full load.
Operating temperature: -20 °F (-29 °C) to 122 °F (50 °C). Must utilize cold weather starting kit for operation below 32 °F (0 °C).

Maintenance and user interface locations

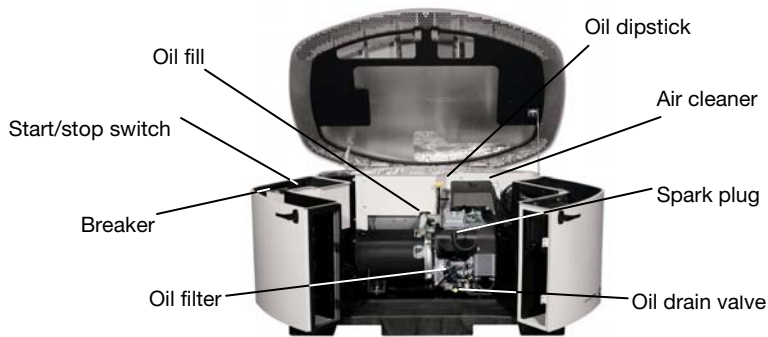

Note: For more information see Operator and Installation manuals, obtain drawing 0500-4905, and wiring diagram 0630-3514 from your distributor/dealer.

Automatic transfer panel configurations

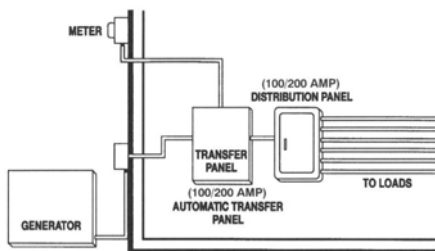

Service entrance installation (USA only) (100/200 A)

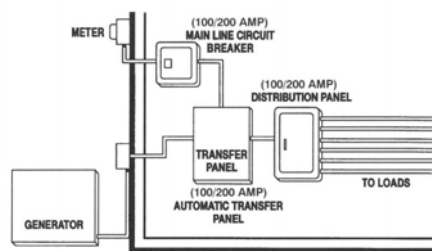

Service entrance installation (USA and Canada) (100/200 A)

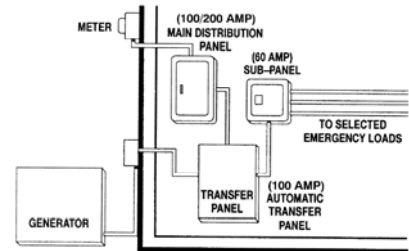

Dedicated emergency standby service system (100/200 A) (USA and Canada)

Cummins®, Onan®, the "C" logo and Performance you rely on.™ are servicemarks, trademarks and/or registered trademarks of Cummins Inc. Specifications subject to change without notice. Other company, product or service names may be trademarks or service marks of others. ©2008 Cummins Power Generation. All Rights Reserved. A-1534b (4/08)

Dimensions – 0500-4905

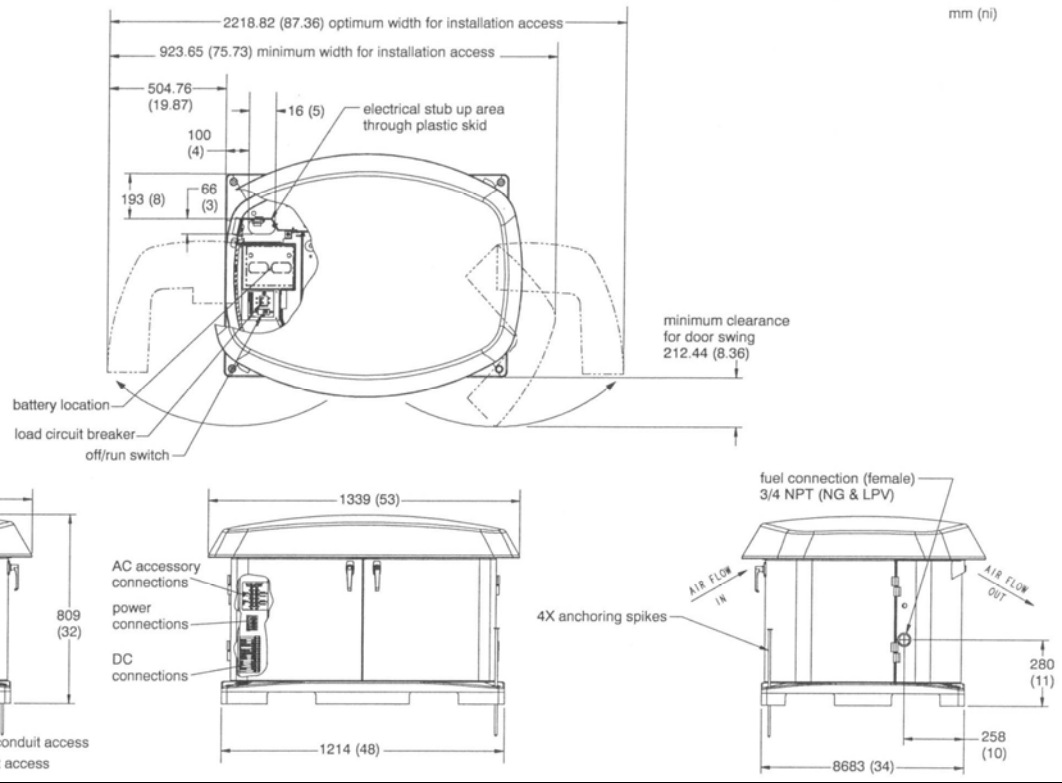

UL 1008 Listed: RSS100-6868, RSS200-6869 (0500-4824)

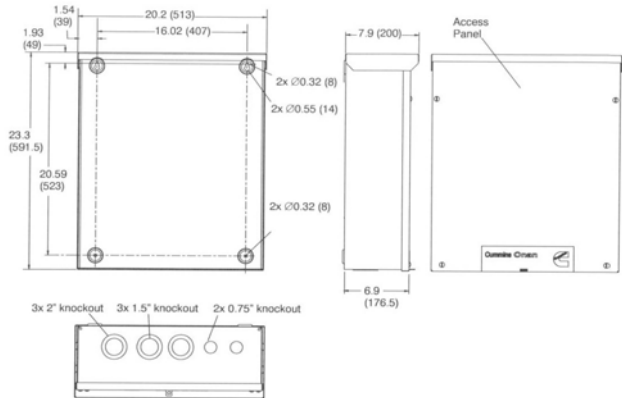

CSA/UL RSS100-6634 (0500-4502)

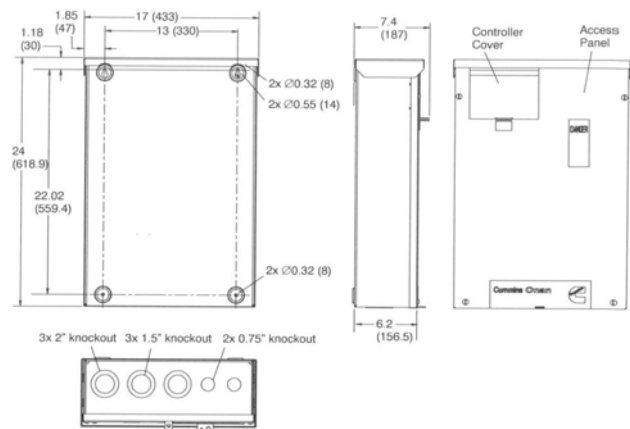

CSA/UL RSS200-6635 (0500-4503)

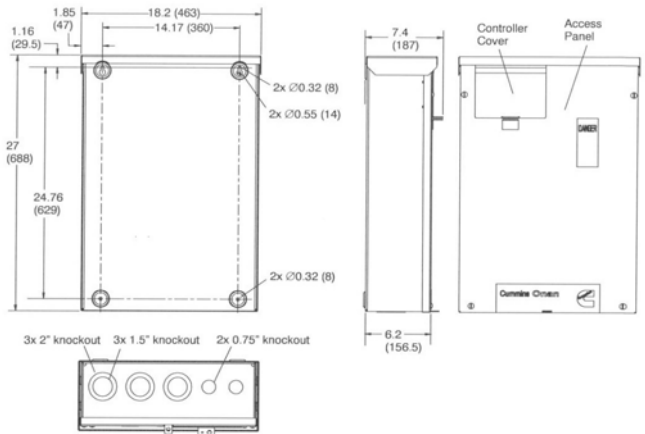

Cummins®, Onan®, the "C" logo and Performance you rely on.™ are servicemarks, trademarks and/or registered trademarks of Cummins Inc. Specifications subject to change without notice. Other company, product or service names may be trademarks or service marks of others. ©2008 Cummins Power Generation. All Rights Reserved. A-1534b (4/08)

Options and accessories

- Battery heater kit (P/N 0333-0770)
- Cold weather starting kit (P/N 0333-0771)
- Installation wheel kit (P/N 0541-1624)

Battery requirement

- 12 V, group 26R, 530 CCA

Testing and standards

- Generator Listed to UL 2200 and CSA, transfer switch Listed to UL 1008.
- This generator set was designed and manufactured in facilities certified to ISO 9001.
- RSS100-6634 and RSS200-6635 meet UL 1008 and CSA requirements.

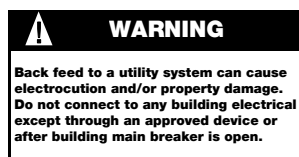
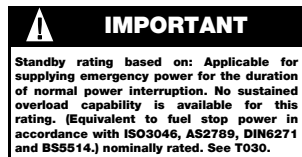

Warranty policy

The Cummins Onan RS12000 home standby system comes with a standard two year/2,000 hour limited warranty. Warranty is valid on all RS12000 generators only when sold with Cummins Onan RSS model transfer switches. A one year/1000 hour warranty will apply if the RS12000 generator is used in an off-grid application or if it is used with any other transfer switch. The RS12000 generator set (12GSAA-6707) and RSS service entrance rated transfer switches (RSS100-6868 and RSS200-6869) are specifically designed to function together. Using any other product in conjunction with model RSS100-6868 or RSS200-6869 will void the warranty. The RSS standard transfer switch (RSS100-6634 and RSS200-6635) may be used with other generators.

Contact your distributor/dealer for more information.

After sale support

Largest distributor/dealer support network

Cummins Onan generator sets are supported by the largest and best trained worldwide certified distributor/dealer network in the industry. This network of knowledgeable distributor/dealers will help you select and install the right generator set and accessories to meet the requirements of your specific application. This same network offers a complete selection of commonly used generator set maintenance parts, accessories and products plus manuals and specification sheets. Plus, they can answer your questions regarding proper operation, maintenance schedules and more.

Manuals: Operation and installation manuals ship with the generator set. To obtain additional copies or other manuals for this model, see your distributor/dealer and request the following manual numbers: Operation (983-0104), Installation (983-0603) Parts (983-0204) Service (983-0503).

To easily locate the nearest certified distributor/dealer for Cummins Onan generators in your area, or for more information, contact us at 1-800-888-6626 (or 763-574-5000) or visit www.cumminsonan.com.

Cummins Onan

Cummins Power Generation

1400 73rd Ave. NE
Minneapolis, MN 55432 USA
Phone 1 763 574 5000
Toll-free 1 800 888 6626
Fax 1 763 574 5298
Email www.cumminsonan.com/contact
www.cumminsonan.com

Cummins®, Onan®, the "C" logo and Performance you rely on.™ are servicemarks, trademarks and/or registered trademarks of Cummins Inc. Specifications subject to change without notice. Other company, product or service names may be trademarks or service marks of others.
©2008 Cummins Power Generation. All Rights Reserved.
A-1534b (4/08)

