

Residential generator

RS Series

30000



Cummins Onan



Performance you rely on.™

Features and benefits

- Very quiet operation - 67 dB(A) at 7 m
- Aluminum weather resistant housing
- Fully automatic operation when used with a Cummins Onan automatic transfer panel
- Available for use with natural gas or LP vapor
- Attractive and discreet housing
- Electronic governor for precise frequency control
- Includes 120 V coolant heater
- Listed to UL 2200

Weight, size and sound level

Weight: 1300 lb (590 kg)

Size: Footprint dimensions (for recommended installation) length 64.4 in (1635 mm), width 30 in (762 mm), height 46.7 in (1184.89 mm)

Overall dimensions: length 85.3 in (2166.68 mm), width 30 in (762 mm), height 46.7 in (1184.89 mm)

Sound: 67 dB(A) at 7m, average

Models and ratings

Order model	Fuel	Voltage	Rated kW	kVa	Rated amps	Circuit breaker
30GGMC-6112	Natural gas	120/240	29	29	242/121	150 A, 2 pole
30GGMC-6113	LP vapor	120/240	30	30	250/125	150 A, 2 pole

Site derating factors:

Natural gas

Engine power available up to 3000 ft (915 m) at ambient temperatures up to 104 °F (40 °C). Above 3000 ft (915 m) derate at 4% per 1000 ft (305 m), and 1.1% per 10 °F (2% per 10 °C) above 104 °F (40 °C).

Propane

Engine power available up to 500 ft (152.4 m) at ambient temperatures up to 104 °F (40 °C). Above 500 ft (152.4 m) derate at 4% per 1000 ft (304.8 m), and 1.1% per 10 °F (2% per 10 °C) above 104 °F (40 °C).

Standard features

Engine:

- Electronic ignition
- Electronic governor
- Full-pressure lubrication
- High-capacity oil sump, spin-on oil filter
- Solenoid shift starter
- 40 A, engine-driven battery charger

Control system:

- Automatic remote starting
- Controls generator set starting and shutdown
- Control components designed to withstand the vibration levels typical in generator sets
- Field circuit breaker
- High temperature, low oil pressure, overcrank and over speed shutdowns
- Running time meter
- 150 A UL Listed circuit breaker
- DC control fuse

Exhaust muffler:

- Enclosed exhaust silencer
- Low noise

Average fuel consumption:

Fuel consumption-natural gas

<u>Load:</u>	<u>1/4</u>	<u>1/2</u>	<u>3/4</u>	<u>Full</u>
Ft ³ /hr:	181.2	259.3	338.1	420
m ³ /hr:	5.1	7.3	9.6	11.9

Fuel consumption-propane

<u>Load:</u>	<u>1/4</u>	<u>1/2</u>	<u>3/4</u>	<u>Full</u>
Ft ³ /hr:	64	91.7	119.6	148.3
m ³ /hr:	1.8	2.6	3.4	4.2

Engine details

Engine: GM industrial, spark-ignited

Design: In-line 4-cylinder, liquid-cooled

Compression ratio: 10:5:1

Displacement: 181 cu in (3.0 L)

Cooling system: 122 °F (50 °C) ambient cooling system

Oil Sump capacity: 4.5 qt (4.3 L) with filter

Operating speed: 1800 RPM

Alternator details

Design: Brushless, revolving field, single bearing, 4-pole, drip-proof construction.

Insulation system: Class H per NEMA MG1-1.65 and BS2757.

Temperature rise: At rated load is less than 125 °C at standby rating, per NEMA MG1.22.40, IEEE 115 and IEC 34-1.

Exciter type: The excitation system derived is a self-excited (shunt) system with the voltage directly from the generator set output.

Alternator cooling: Direct drive centrifugal blower.

Rotor: Supported by a pre-lubricated maintenance-free ball bearing.

AC wave form total harmonic distortion: less than 5% total no load to full load.

Generator performance

Voltage: 120/240 V AC, single phase, 1.0 pf.

Voltage regulation: ±1%, no load to full load.

Frequency regulation: Isochronous, 0% no load to full load.

Random frequency variation: ±0.5% at 60 Hz.

Operating temperature: -20 °F (-28.8 °C) to 122 °F (50 °C).

Basic dimensions

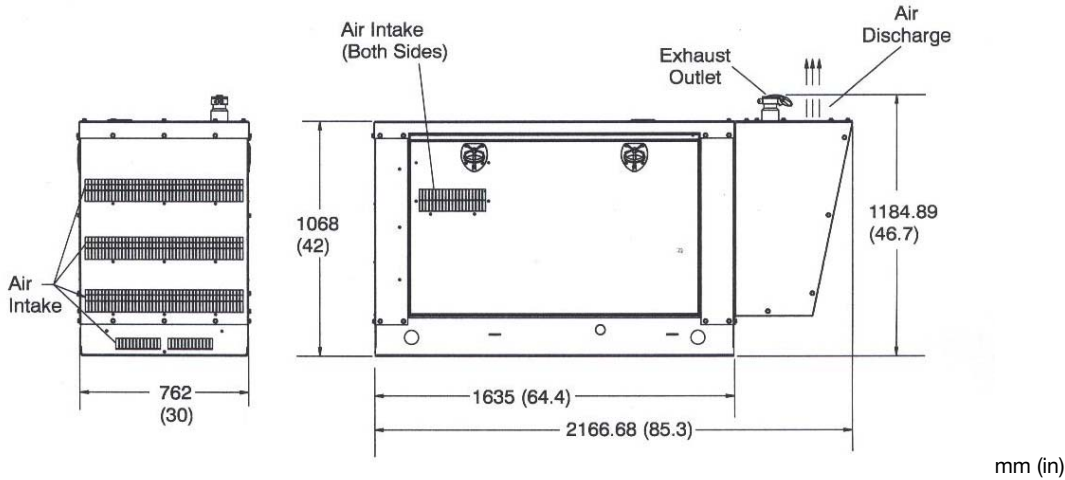

Note: This outline drawing is provided for general reference only and is not intended for design or installation. For more information see Operation and Installation manuals or obtain drawing 500-4511 or 500-4512 and wiring diagram from your distributor/dealer.

Installation drawing

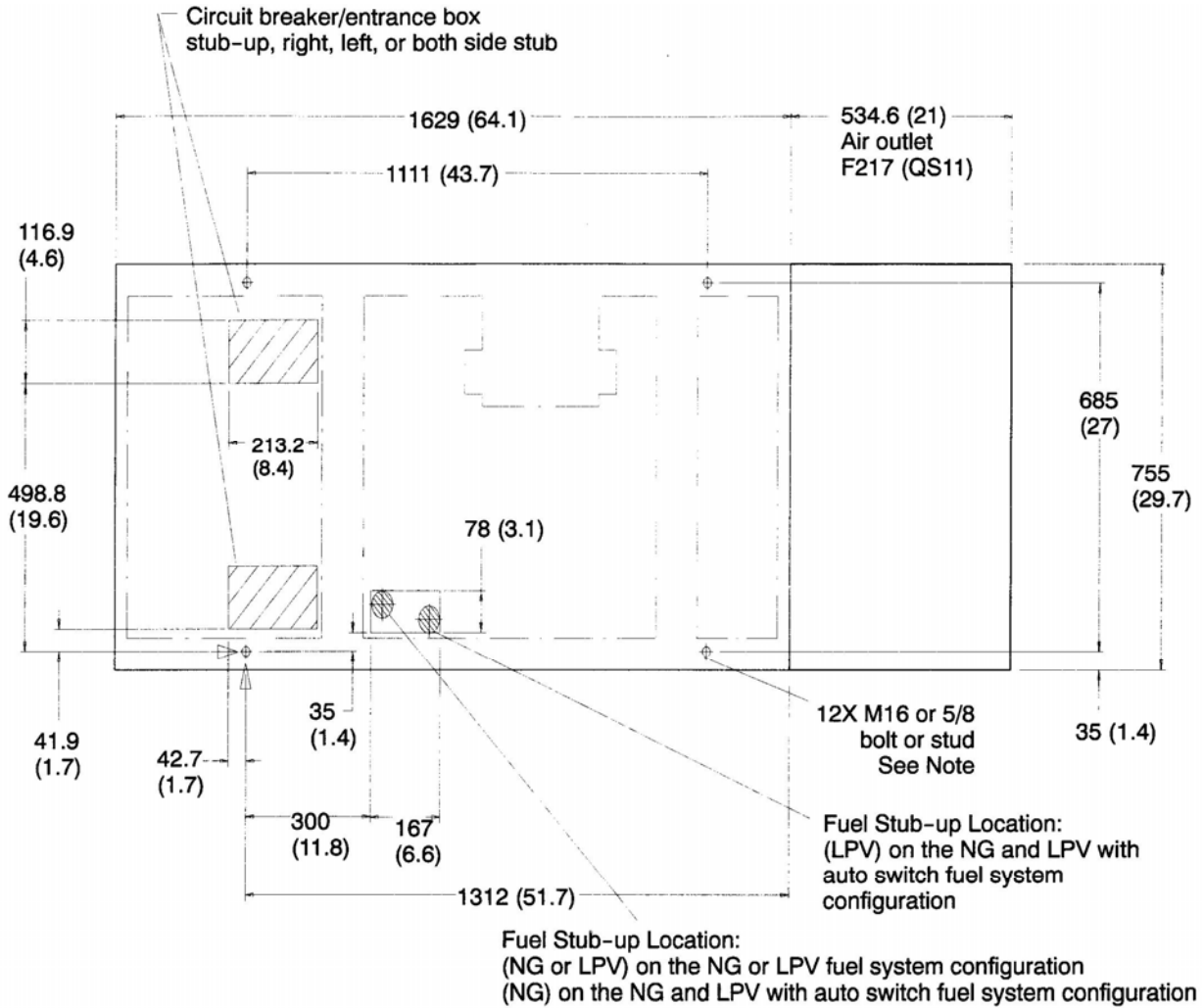

Note: Skid-base has a flange thickness of 3.42 mm (.135 inches)
 Allow extra length on hardware for unevenness of mounting surface.

mm (in)

Automatic transfer panel configurations

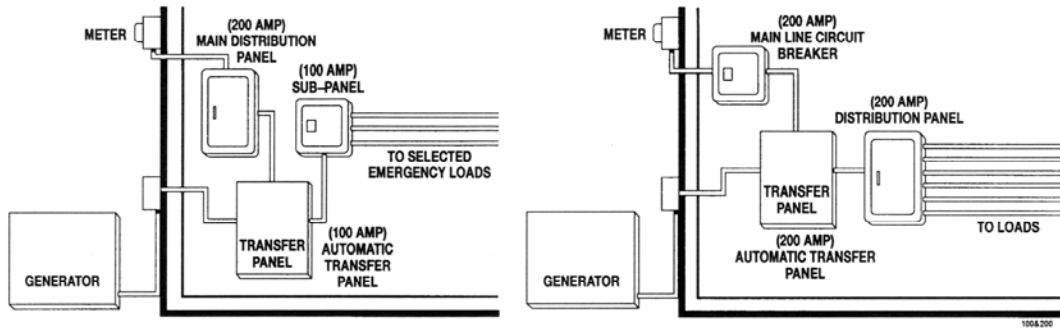

Dedicated emergency standby service system (100 A)

Full-service rating standby system (200 A)

Options and accessories

- Battery, 12 V, 325 cca (P/N 416-0774)
- Battery heater kit (P/N 333-0469)
- Full line of complementing automatic transfer panels

Housing features

- Weather protective design, two easy service access doors - key-lockable
- Internal starting battery tray and tie down
- Heavy-duty aluminum housing

Testing and standards

- Listed to UL 2200
- This generator set was designed and manufactured in facilities certified to ISO 9001.
- CSA-certified for electrical equipment. Meets CSA C22.2.



Warranty policy

The Cummins Onan RS 30000 home standby system comes with a standard two-year warranty. Additional two and five-year warranty options are available. See your certified distributor or dealer for details.

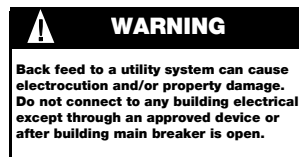
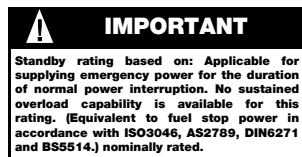

(See T-030 document for more information.)

After sale support

Largest distributor/dealer support network

Cummins Onan generator sets are supported by the largest and best trained worldwide certified distributor/dealer network in the industry. This network of knowledgeable Cummins Onan distributor/dealers will help you select and install the right generator set and accessories to meet the requirements of your specific application. This same network offers a complete selection of commonly used generator set maintenance parts, accessories, and products plus manuals and specification sheets. Plus, they can answer your questions regarding proper operation, maintenance schedules and more.

Manuals: Operation and installation manuals ship with the generator set. To obtain additional copies or other manuals for this model, see your Cummins Onan distributor/dealer and request the following manual numbers: Operation (961-0117), Installation (961-0615), Parts (961-0214), Service (961-0510).

To easily locate the nearest Cummins Onan distributor/dealer in your area, or for more information, contact us at 1-800-888-6626 (or 763-574-5000), or visit www.cumminsonan.com.

Contact your distributor/dealer for more information.

Cummins Onan

Cummins Power Generation

1400 73rd Ave. NE
 Minneapolis, MN 55432 USA
 Phone 1 763 574 5000
 Toll-free 1 800 888 6626
 Fax 1 763 574 5298

Email www.cumminsonan.com/contact
www.cumminsonan.com

Cummins®, Onan®, the "C" logo and Performance you rely on.™ are servicemarks, trademarks and/or registered trademarks of Cummins Inc. Specifications subject to change without notice ©2008 Cummins Power Generation. All Rights Reserved.
 A-1493a (3/08)

